

# JUNIPER®

## THIN SINGLE FLOAT - Junction Box-Mounted Remote Installation Guide

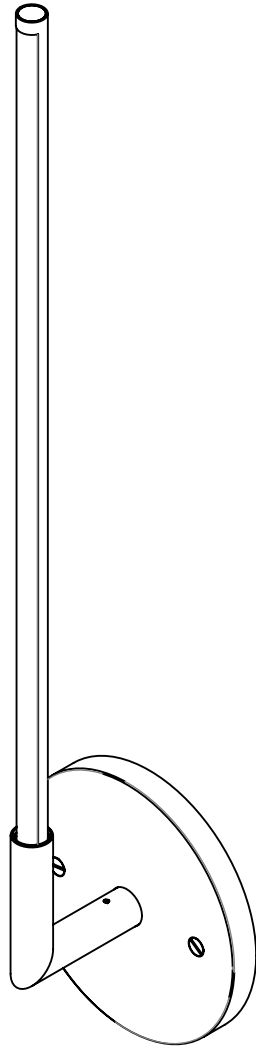

18 IN

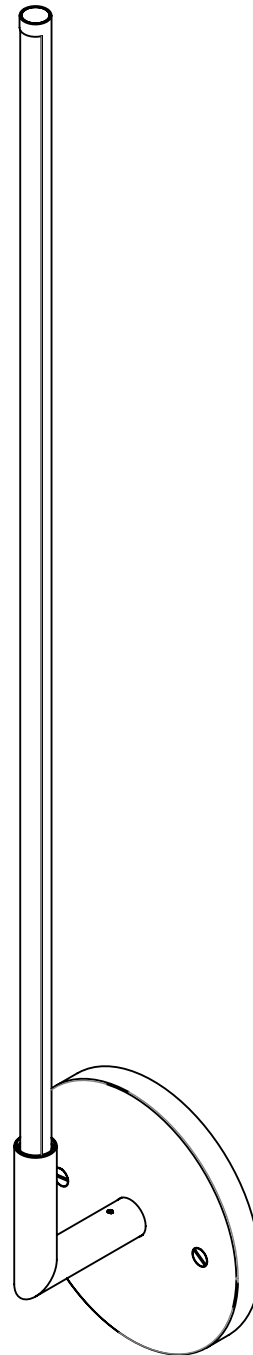

24 IN

**WARNING**

**A LICENSED ELECTRICIAN SHOULD PERFORM INSTALLATION.  
DISCONNECT MAIN POWER AT THE SOURCE PRIOR TO INSTALLATION.**

**INSTRUCTIONS MEANT FOR A REMOTE CLASS 2 DRIVER.**

**STEP 1: INSTALLING THE FIXTURE**

**1**

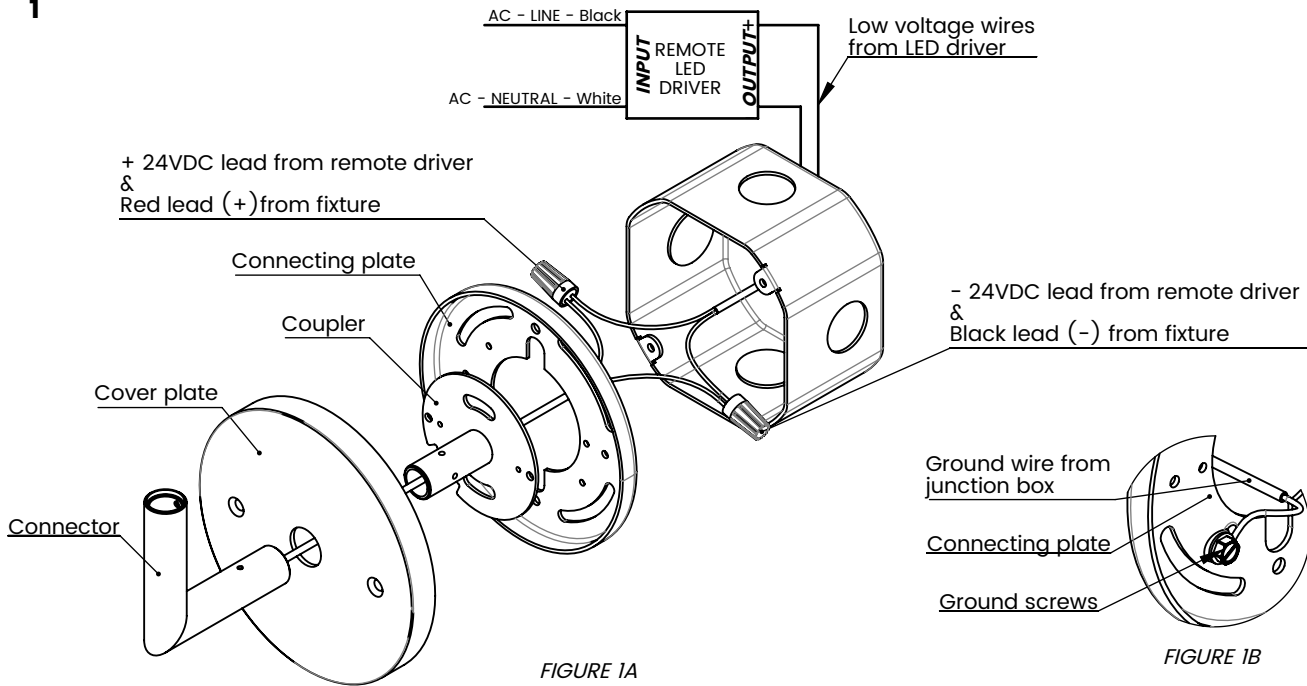

<PARA >

- A. Pass the wires coming out of the connector through the cover plate, coupler and connecting plate as shown in figure 1A.
- B. Connect the wires coming out of the connector to LED driver's output wires using provided blue/grey wire nuts as shown in figure 1A.
- C. <PARA >Connect ground wire to ground screw on connecting plate as shown in figure 1B.

**Wires to and from the LED driver are not provided.**

**2**

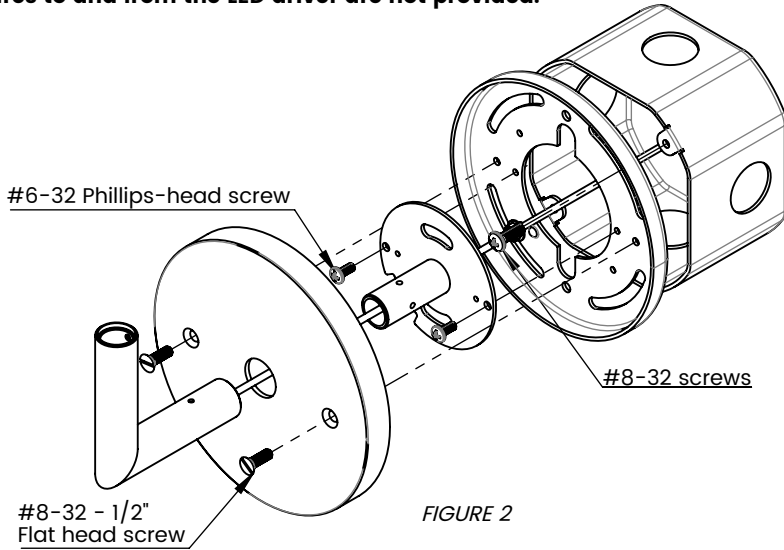

**3**

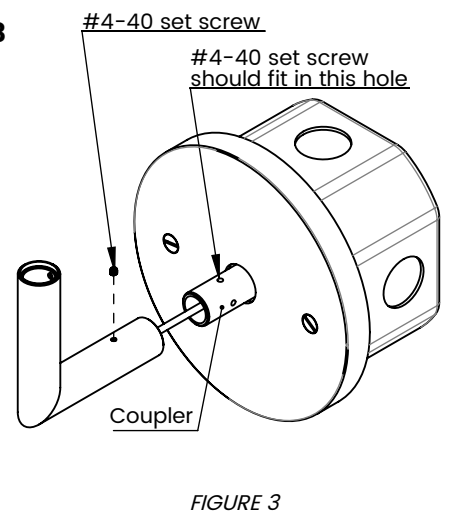

- A. Place the connected wires and LED driver inside junction box.
- B. Install connecting plate on junction box using provided #8-32 Phillips-head screws.
- C. Install coupler on connecting plate using provided #6-32 Phillips-head screws.
- D. Install cover plate on connecting plate using provided #8-32-1/2" flat head screws. Ensure that the screws are horizontally in line. If required, loosen the #8-32 Phillips-head screws on the connecting plate to adjust its orientation.

Install connector on the coupler using provided #4-40 set screw as shown. Make sure that the set screw fits inside the hole in the coupler. **If the connector is not aligned correctly, remove the connector and cover plate. Loosen the #8-32 Phillips-head screws to adjust the orientation of connecting plate.**

**STEP 2: INSTALLING LIGHT TUBE**

The fixture is designed with an innovative magnetic connection. Simply insert the light tubes into the connectors for electrical contact to be made.

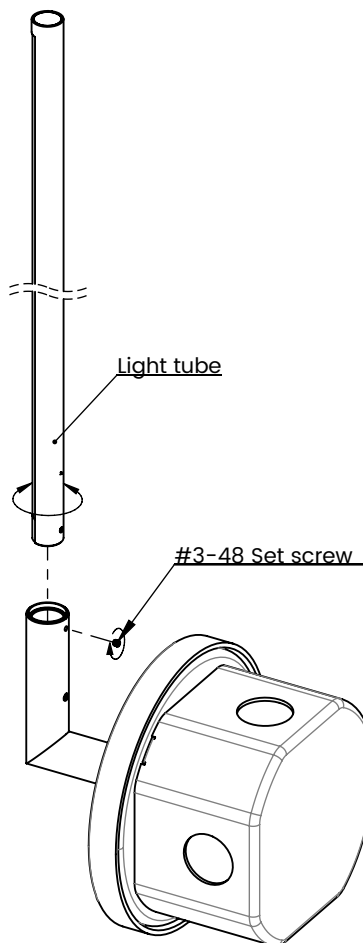

FIGURE 4

- A. Insert light tube into the connector.
- B. Rotate the light tube to adjust orientation.
- C. Use provided #3-48 set screw to lock light segment in place.

**CARE INSTRUCTIONS**

Brass will patina over time like other natural metals and regular care is required in order to retain the quality finish of your fixture for years to come.

Gently wipe with a damp cloth to remove dirt, dust, and fingerprints.

Do not use any chemical cleaning solution.

Use indoors only.