

# JUNIPER<sup>®</sup> Metropolis Suspension Local Unison Dimming Installation Guide

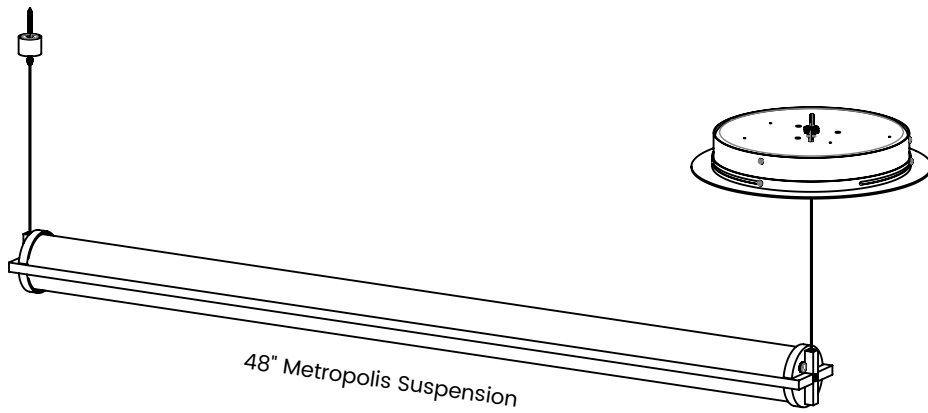
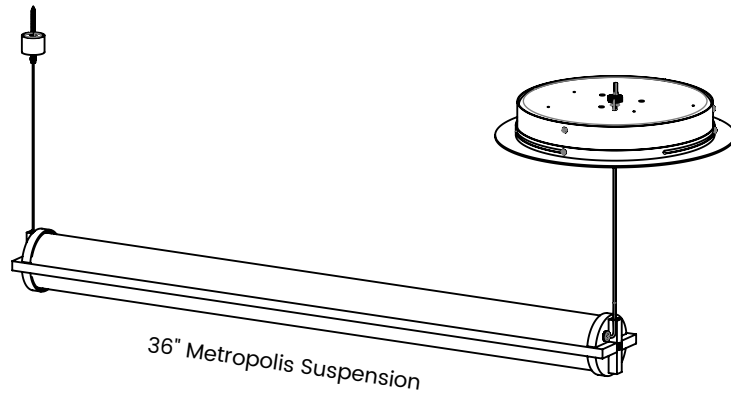

**WARNING**

**A LICENSED ELECTRICIAN SHOULD PERFORM INSTALLATION. DISCONNECT MAIN POWER AT THE SOURCE PRIOR TO INSTALLATION.**

**INSTRUCTIONS MEANT FOR LOCAL CLASS 2 DRIVER.**

**DUE TO HEAVY WEIGHT OF THE FIXTURE, EXTRA CAUTION IS REQUIRED WHEN HANDLING.**

**PREFERABLY, TWO PEOPLE SHOULD BE INVOLVED IN THE INSTALLATION OF THE FIXTURE.**

**STEP 1: MARK MOUNTING POINTS**

Carefully mark the mounting points, using the spacing in Figure 1. **It is highly recommended to use a laser alignment/measuring tool to ensure that mounting points are properly distanced.**

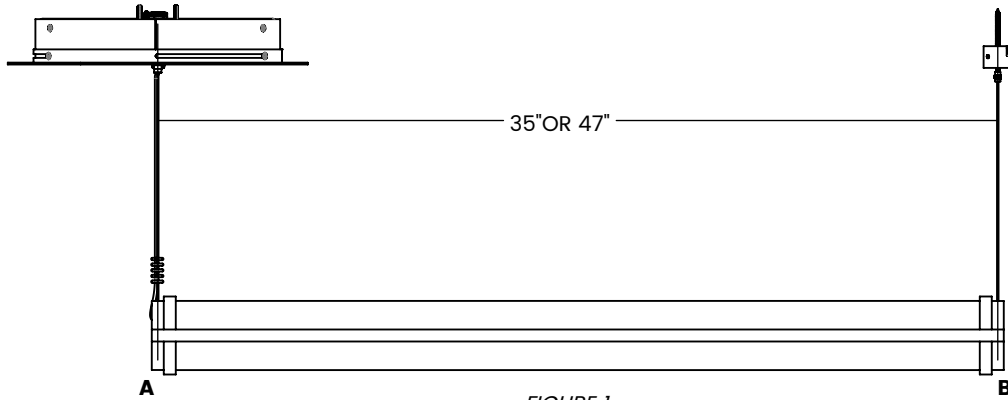

FIGURE 1

**KEY**

- A POWER END** CANOPY PLATE IS MOUNTED AT POWERED END OF THE FIXTURE.
- B CEILING POST** MOUNTED AT THE NON-POWERED END OF THE FIXTURE.

**STEP 2: FIXTURE INSTALLATION**

**POWER END (A)**

**1**

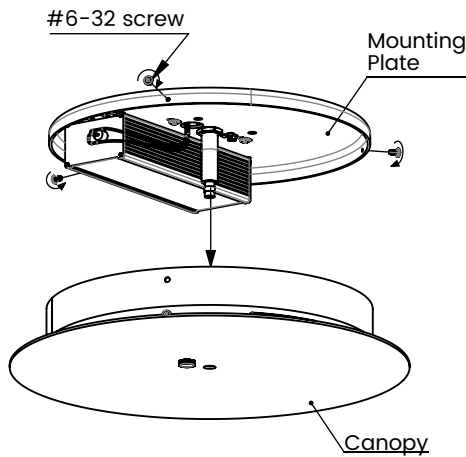

FIGURE 2

Remove #6-32 screws from the canopy to release the mounting plate.

**2**

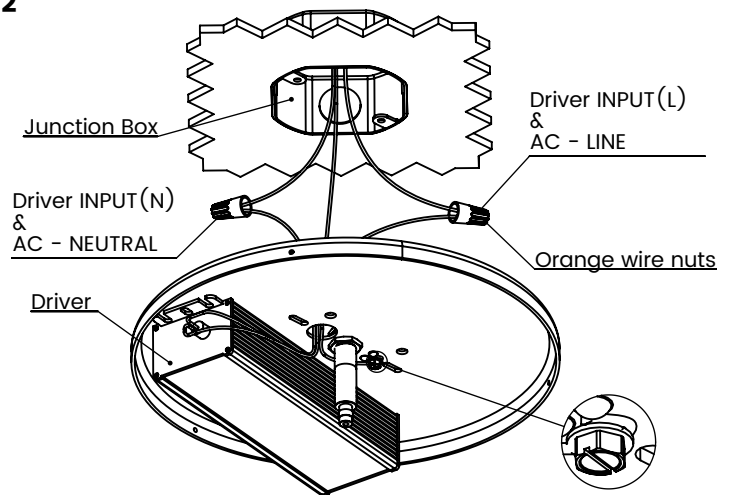

FIGURE 3

Connect the ground wire to ground screw

As shown above, make electrical connections between the **AC** input of the driver and the **AC** wires present in the electrical box. Use provided orange wire nuts,

**AC wires to the drivers are not provided.**

3

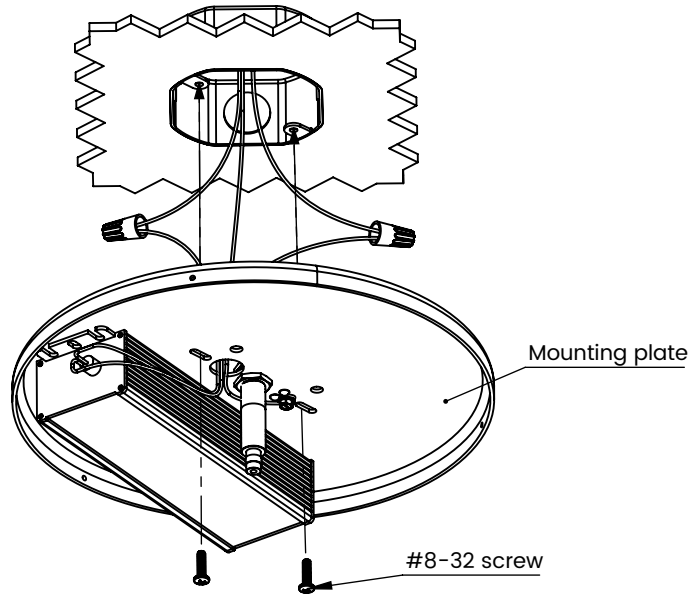

FIGURE 4

Attach mounting plate to the junction box using provided #8-32 screws.

4

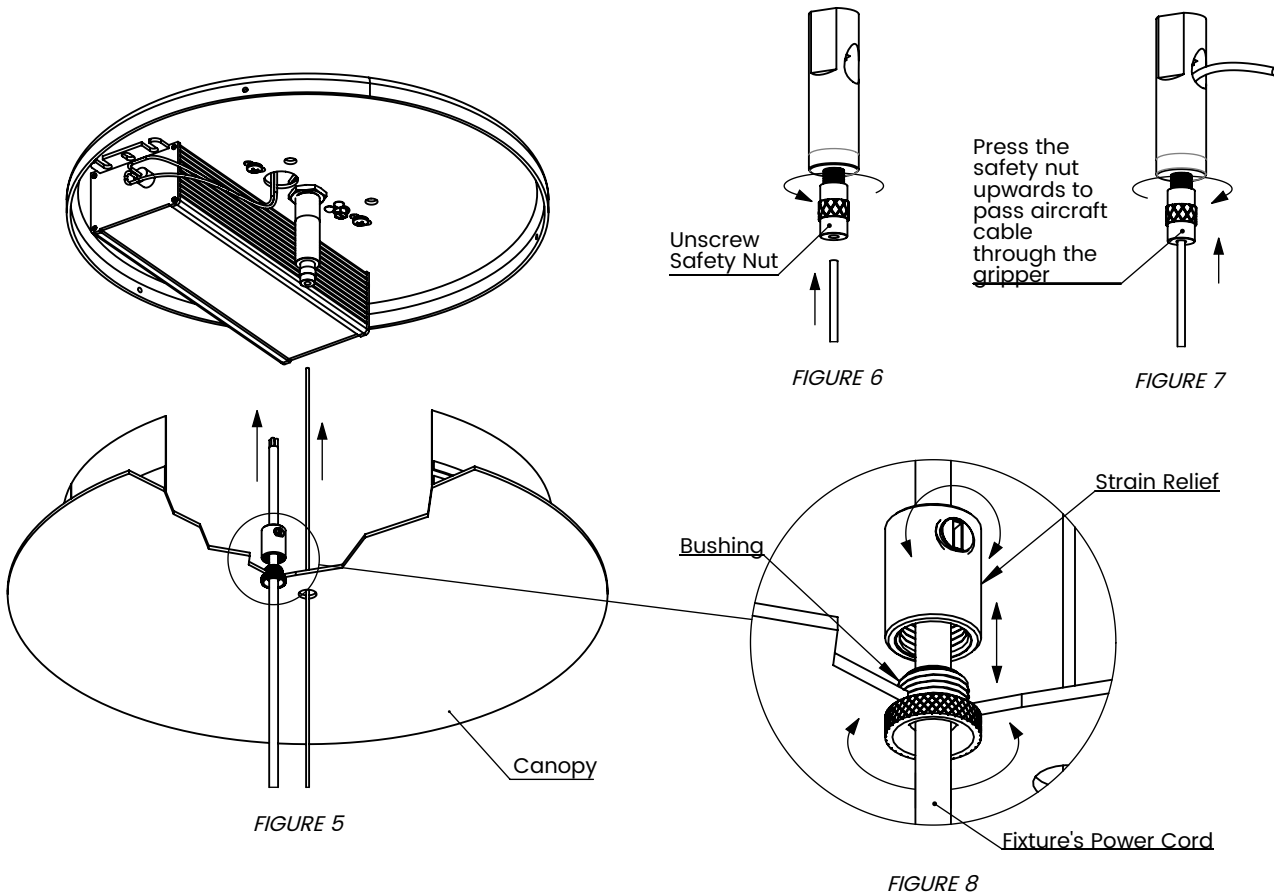

FIGURE 5

FIGURE 6

FIGURE 7

FIGURE 8

Pass the aircraft cables through the canopy. Partly loosen safety nut on cable gripper. Feed aircraft cable through the gripper. Adjust the cable length as needed by pressing the safety nut on the gripper. Tighten safety nut in completely when finished. **Do not cut extra aircraft cable until full fixture is assembled and desired suspension height is achieved.**

Remove the strain relief by unscrewing the bushing. Loosen set screw on the strain relief. Pass the fixture's power cord through the bushing and strain relief. Tighten the set screw, leaving some slack in the power cord. Screw strain relief into the bushing.

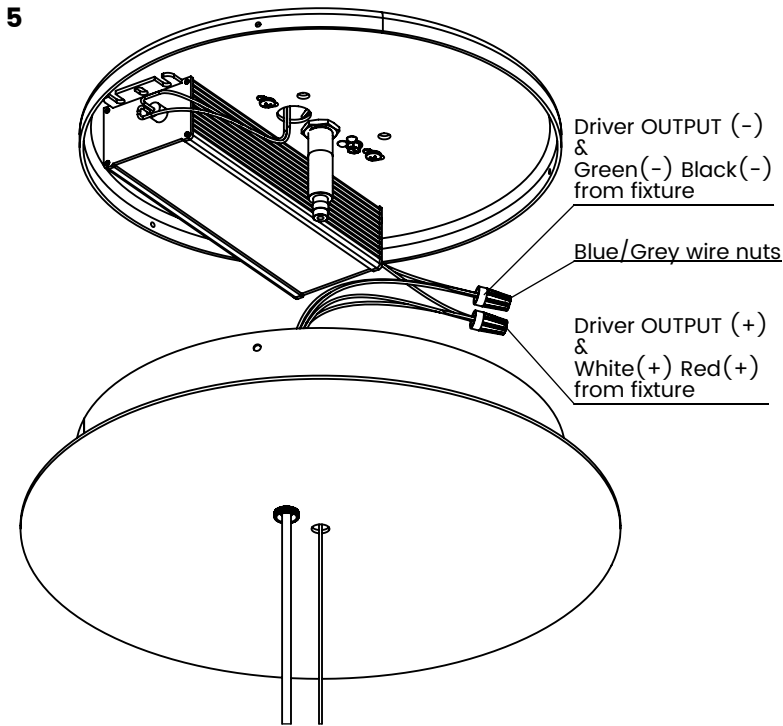

FIGURE 9

Connect wires from fixture to driver's output according to diagram by using provided **blue/grey** wire nuts.

**CEILING POST (B)**

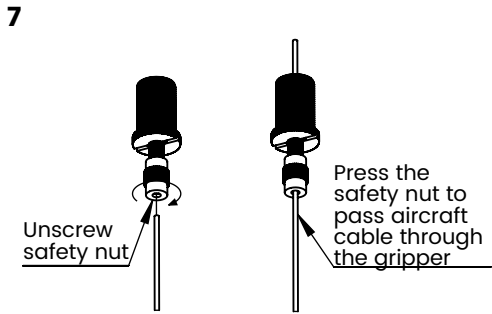

FIGURE 11

Partly loosen safety nut on cable gripper. Feed aircraft cable through the gripper.

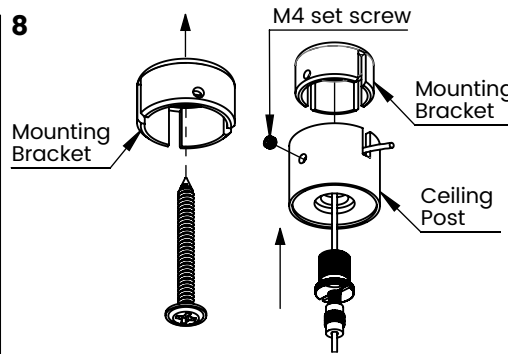

FIGURE 12

Install mounting bracket at mounting point B using provided #8 wood screw. Pass the extra aircraft cable through the slot in ceiling post and screw gripper into ceiling post. Attach ceiling post to mounting bracket using provided M4 set screw. Alternate screws may be used at the recommendation of an electrician.

**Use the slot on mounting bracket to make finer adjustment to mounting positions.**

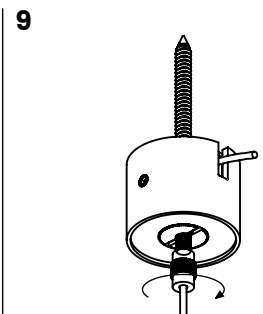

FIGURE 13

Adjust aircraft cable length as needed. Press safety nut on gripper to loosen aircraft cable. Tighten safety nut in completely when finished. **Do not cut extra aircraft cable until full fixture is assembled and desired suspension height is achieved.**

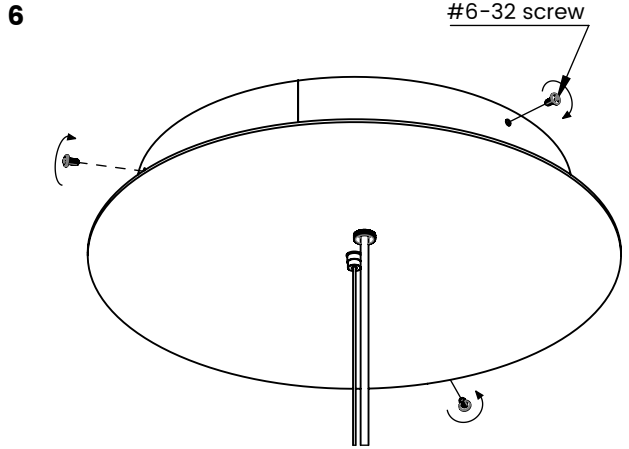

FIGURE 10

Install the canopy on mounting plate using #6-32 screws removed during the first instruction.

**STEP 3: CONSTRAINING THE POWER CORD**

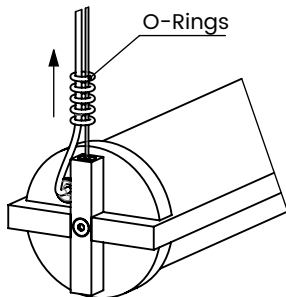

FIGURE 14

Space the O-rings apart at the power end along the length of the power cable to constrain the power cord to aircraft cable.

**CARE INSTRUCTIONS**

- Gently wipe with a damp cloth to remove dirt, dust, and fingerprints.
- Do not use any chemical cleaning solution.
- Use indoors only.